



**BACKHOE**

**RE760K**



## POWER SHIFT BACKHOE LOADER

AMOUNT	1
BRAND	YANWA
MAKER	YANWA
MODEL	RE760K
YEAR OF PRODUCTION	2023
ORIGIN	CHINA
COLOR	ORANGE
OPERATIONAL WEIGHT	7.6 TON /7600 KG

## STANDARD DIMENSIONS

LONG	6970MM
TOTAL WIDTH	2280MM
CABIN HEIGHT	2876MM
DISTANCE BETWEEN AXIS	2210MM

## DIRECTION SYSTEM

TYPE	HYDROSTATIC / LOAD SENSOR
------	---------------------------



## ENGINE

BRAND	CUMMINS
MODEL	QSB4,5-C110
TYPE	4-STROKE INTERNAL COMBUSTION
FUEL	DIESEL
GROSS POWER	110 HP (82 KW) @ 2200 RPM
NET POWER	108 HP (80 KW) @ 2200 RPM
OPERATING REGIME	2200RPM
DISPLACEMENT	4.5L
EMISSIONS SYSTEM	TIER III
CYLINDER CAPACITY	4500CC
MAXIMUM TORQUE (TORQUE)	480 NM @ 1500RPM (354.42 LBF.FT /49.76 KGF.M)
NUMBER OF CYLINDERS	4 IN LINE
INJECTION SYSTEM	DIRECT (COMMON RAIL)
AIR SUPPLY	TURBOCHARGED
FUEL TANK CAPACITY	150 LITERS
REFRIGERATION	WATER

## CABIN (FULL EQUIPMENT)

CABIN	CLOSED
TYPE	ROPS (ISO 3741) / FOPS (ISO 3449)
A/C	INCLUDES
ERGONOMIC / ADJUSTABLE SEAT	INCLUDES
SAFETY BELT (TWO POINTS)	INCLUDES
RADIO (BLUETOOTH+USB+AM/FM)	INCLUDES
ENTRANCE BOTH SIDES (LEFT - RIGHT)	INCLUDES
ADJUSTABLE STEERING WHEEL	INCLUDES
MIRRORS	INCLUDES
NOISE INSIDE THE CABIN	72.3DB(A)
NOISE OUTSIDE THE CABIN	82.4DB(A)

## WHEELS

FRONT	DIMENSIONS 14-17.5 CANVAS 14 (PLY) MAX LOAD 3875KG
LATER	DIMENSIONS 19.5L-24 CANVAS 14 (PLY) MAX LOAD 3540KG



## DASHBOARD - INCLUDES

TACHOMETER	INCLUDES
HYDROMETER	INCLUDES
HOUR METER	INCLUDES
SPEEDOMETER	INCLUDES
TEMPERATURE GAUGE	INCLUDES
SEDIMENT INDICATOR	INCLUDES
AIR FILTER OBSTRUCTION INDICATOR	INCLUDES
PARKING BRAKE WARNING LIGHT	INCLUDES
AIR FILTER INDICATOR LIGHT	INCLUDES
WARNING LIGHTS	BATTERY ALARM ENGINE ALARM PREHEAT ALARM OIL TEMPERATURE ALARM

## TRANSMISSION SYSTEM

TRACTION	4WD (4X4)
TYPE OF BOX	POWERSHIFT
SPEEDS	4 FORWARD / 4 REVERSE
TOP SPEED 1ST (FORWARD /REVERSE)	6.5 KM/H
2ND MAX SPEED (FORWARD /REVERSE)	11.1 KM/H
TOP SPEED 3RD (FORWARD/ REVERSE)	23.2KM/H
TOP SPEED 4TH (FORWARD/ REVERSE)	40.3 KM/H
TRACTION CONTROL	AUTOMATIC/LEVER TO SELECT SPEEDS
REAR DIFFERENTIAL INCLUDES	HYDRAULIC LOCK ACTIVATOR (CAB BUTTON)

## BRAKES

SERVICE BRAKE	MULTIPLE DISC - OIL BATH INCORPORATED INTO REAR AXLES FREE ADJUSTMENT HYDRAULIC ACTUATOR
PARKING BREAK	ELECTRIC SWITCH IN CABIN

## HYDRAULIC SYSTEM

PUMP TYPE	TANDEM GEAR PUMP
MAIN RELIEF PRESSURE	24MPA
FLOW	143 L/MIN
PUMP FLOW	143 L/MIN
TYPE OF SYSTEM	OPEN CENTER
TYPE OF ADDRESS	PRIORITY VALVE
SYSTEM PRESSURE (BACKHOE)	248 BAR (253 KG/CM2)
SYSTEM PRESSURE (CHARGER)	248 BAR (253 KG/CM2)
LOADER AND EXCAVATOR DRIVE	MANUAL LEVERS
DEPOSIT CAPACITY	41LT
HYDRAULIC SYSTEM CAPACITY	97LT
CONTROL TYPE	JOYSTICK TYPE: ELECTRO-HYDRAULIC CONTROL WITH PRESSURE CHANGE VALVE

## WHEELS

FRONT	DIMENSIONS 14-17.5 CANVAS 14 (PLY) MAX LOAD 3875KG
LATER	DIMENSIONS 19.5L-24 CANVAS 14 (PLY) MAX LOAD 3540KG

## EXCAVATOR ARM

TYPE	HYDRAULIC (STANDARD)
CONTROLS	JOY STICK
BUCKET CAPACITY (ISO 7451 STANDARD)	0.2 M3
BUCKET WIDTH	610MM
MAXIMUM REACH FROM PIVOT CENTER TO GROUND	6702MM
DIGGING HEIGHT	5522MM
DIGGING DEPTH	4440MM
NUMBER OF TEETH	5
DIGGING FORCE	BUCKET: 13,448 LBF / 6,100 KGF / 59.8 KN ARM: 8,818 LBF / 4,000 KGF / 39.22 KN
BUCKET ANGLE OF ROTATION	186°
BOOM SYSTEM:	LOCK AND UNLOCK SYSTEM HYDRAULIC DRIVE TYPE BY SWITCHIN CABIN

## HYDRAULIC SYSTEM

PUMP TYPE	TANDEM GEAR PUMP
MAIN RELIEF PRESSURE	24MPA
FLOW (PUMP FLOW)	143 L/MIN
TYPE OF SYSTEM	OPEN CENTER
TYPE OF ADDRESS	PRIORITY VALVE
SYSTEM PRESSURE (BACKHOE)	253 KG/CM2 (3600 LB/IN2)
SYSTEM PRESSURE (CHARGER)	253 KG/CM2 (3600 LB/IN2)
DEPOSIT CAPACITY	41LT
HYDRAULIC SYSTEM CAPACITY	97LT
CONTROL TYPE	JOYSTICK TYPE: ELECTRO-HYDRAULIC CONTROL WITH PRESSURE CHANGE VALVE

## CHARGER

TYPE	HYDRAULIC
CONTROLS	JOY STICK
LOADER BUCKET CAPACITY (ISO 7451 STANDARD)	1.0 M3
BUCKET BREAKOUT/ DIGGING FORCE	14,275 LBF / 6,475 KG / 63.5KN
LIFTING CAPACITY AT MAXIMUM HEIGHT	8,598 LBF / 3,900 KGF / 38.24 KN
LIFTING CAPACITY AT GROUND LEVEL	12,026 LBF / 5,455 KGF / 53.5 KN
DRAWBAR LIFTING CAPACITY	11,082 LBF / 5,027 KGF / 49.3 KN
BUCKET WIDTH	2260MM
MAX DUMP ANGLE	45° (FULL HEIGHT)
DISCHARGE HEIGHT	2798MM
PIN LOADING HEIGHT	3474MM
MAXIMUM HEIGHT	4404MM
PENETRATION DEPTH (EXCAVATION)	150MM

## ELECTRIC SYSTEM

VOLTAGE	12 VOLT
BATTERY CAPACITY	100 AH
COLD START CAPACITY	850 CCA
ALTERNATOR	120A
STARTING MOTOR	12V

### ELECTRICAL SYSTEM - INCLUDES

WORK LIGHTS (4 FRONT LED LIGHTS / 4 REAR LED LIGHTS)	INCLUDES
ELECTRIC HORN	INCLUDES
BACKUP ALARM	INCLUDES
ROAD TRAFFIC LIGHTS	INCLUDES
PARKING / STOP LIGHTS	INCLUDES

### SERVICE CAPABILITIES

MOTOR OIL	13LT
HYDRAULIC SYSTEM TANK	41LT
FULL HYDRAULIC SYSTEM	97LT
TRANSMISSION AND TORQUE CONVERTER	16LT



# DIMENSIONS

- A maximum height
- B pin height
- BB max height forklift
- C cab height
- D max height download
- E max range discharge (45°)
- F discharge angle
- G pickup angle
- H digging depth
- I bucket reach (transport)
- J ground clearance
- K distance between axis
- L backhoe swing center distance
- M transport length
- N SAE dump height max height download  
-with extended telescopic SAE  
- with telescopic max.
- O digging height -with extended telescopic
- P SAE digging depth -with extended telescopic
- Q reach at maximum height - with extended telescopic
- R max range from the center of rotation - with extended telescopic
- S digging depth - with telescopic arm
- T digging reach
- U distance between rear wheels
- V distance between front wheels
- W overall width (with bucket)
- X backhoe transport height - with telescopic
- Y center distance with stabilizers - fully extended
- YY distance from the center of the stabilizers
- Z distance from the outside of the stabilizers
- ZZ overall width (with bucket)

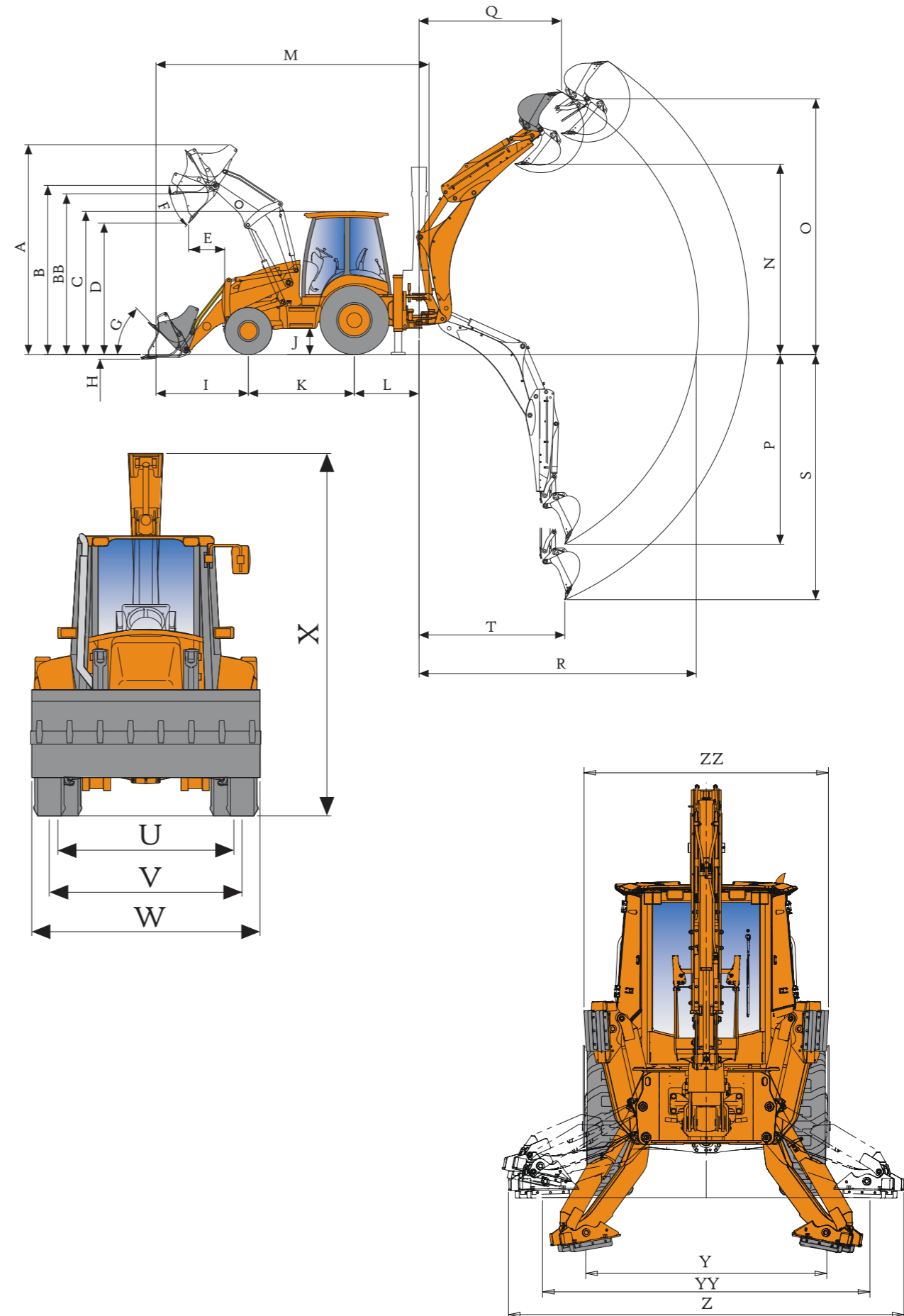

When the machine is used for object handling operations, the backhoe part must be equipped with safety valves (boom, arm and overload warning device) in accordance with EN474-5 and must operate in accordance with the regulations related premises.

## TOOLS (1 KIT PER ROAD TEAM, BACKHOE)

HYDRAULIC BOTTLE JACK	15 TON ACTION LEVER JACK KEY
TYPE I WHEEL WRENCH	32X30 FORCE LEVER
WHEEL LOCK STUDS (2 UNITS)	POLYURETHANE 6,2 KG 39,4X21,6X21 CM (LXAXH)
TOOLBOX	PLIERS SCREWDRIVER PHILLIPS SCREWDRIVER 10" SPANNER COMBINATION WRENCHES (10 TO 23)MM
EXTINGUISHER	PQS TYPE CLASS A,B,C FIRES 10 KG
MEDICINE CABINET	ANTISEPTIC ALCOHOL OXYGENATED WATER POROUS ADHESIVE TAPE GAUZE COTTON BANDAGE (1 TRIANGULAR -1 LONGITUDINAL) SCISSORS ANALGESICS (PARACETAMO IBUPROFEN) GLOVES
FLASHLIGHT	LED TYPE
SAFETY TRIANGLES 2 UNITS	2 UNITS 50 CM EACH SIDE FLUORESCENT SURFACE ABS MATERIAL RED REFLECTIVE PLATE POLYETHYLENE BASE (WEIGHT 2KG)



