



YANWA MC82





TECHNICAL SHEET OF MINI LOADER

SKID STEER

BRAND	YANWA
MODEL	MC82
ORIGIN	CHINA
YEAR	2023
OPERATIONAL WEIGHT	3630KG

STANDARD DIMENSIONS

LENGTH WITH BUCKET AT GROUND LEVEL	3600MM
MACHINE TRACK BETWEEN WHEEL CENTERS	1400MM
CABIN HEIGHT	2000MM
DISTANCE BETWEEN AXIS	1300MM

TECHNICAL SHEET OF MINI LOADER

BRAND	YANWA
MODEL	YW3,2-82
GROSS POWER	82 HP (61 KW)
NET POWER	76 HP (57 KW)
COMBUSTION	INTERNAL 4 TIMES
FUEL	DIESEL
EMISSIONS SYSTEM	TIER 3
CYLINDER CAPACITY	3200CC
MAXIMUM TORQUE	305NM AT 1400RPM
NUMBER OF CYLINDERS	4 IN LINE
INJECTION SYSTEM	DIRECT
AIR SUPPLY	TURBOCHARGED
FUEL TANK CAPACITY	96.5 LITERS
REFRIGERATION	WATER

HYDRAULIC SYSTEM

PUMP TYPE 3600MM

STANDARD PUMP FLOW 85 L/MIN

HYDRAULIC AUXILIARY LINE INCLUDED (FOR ACCESSORIES)

TANK CAPACITY 55.5 LITERS

WHEELS

FRONT DIMENSIONS 12-16.5, 12PR
MAX LOAD 2865KG

LATER DIMENSIONS 12-16.5, 12PR
MAX LOAD 2865KG

DISTANCE BETWEEN AXIS 1300MM





BRAKES

PARKING BREAK

SPRING LOADED
HYDRAULIC DISC DISCONNECT

CHARGER

TYPE

HYDRAULIC

CONTROLS

LEVER

LOADER BUCKET CAPACITY

0.61 M3

BUCKET WIDTH

1800MM (72")

LIFT HEIGHT

4200MM (164.4")

BUCKET HINGE PIN HEIGHT

3300MM (130")

HEIGHT BOTTOM OF BUCKET
LEVEL (WITH ARM FULLY
RAISED)

3100MM (123")

GROUND CLEARANCE

200MM (8")

DUMP ANGLE (MAXIMUM HEIGHT)

53.5°

LOADING CAPACITY

2200 LBS.

TIPPING LOAD

5000 LBS.

BREAKOUT FORCE

ARM 5090 LBF
8585 LBF BUCKET

CABIN

CABIN	CLOSED
FOR CABIN	ROPS /FOPS WITH SIDE SCREENS
FOR STRUCTURE	ROPS /FOPS TILTING
ADJUSTABLE SEAT	INCLUDES
SEAT BELT	INCLUDES
VENTILATION	INCLUDES
A/C	INCLUDES

ELECTRIC SYSTEM

VOLTAGE	12 VOLT
BATTERY	12V 1000CCA
ALTERNATOR	95A

ELECTRIC SYSTEM- INCLUDES

WORK LIGHTS (2 FRONT LED LIGHTS / 2 REAR LED LIGHTS)	INCLUDES
REAR LIGHTS (2 LED WARNING AND INDICATOR LIGHTS)	INCLUDES
ELECTRIC HORN	INCLUDES
BACKUP ALARM	INCLUDES



DASHBOARD

DIGITAL HOUR METER INCLUDES

FUEL LEVEL GAUGE INCLUDES

LOW BATTERY VOLTAGE
WARNING ALARM INCLUDES

ALERT LIGHTS WITH ALARM

ENGINE FLUID TEMPERATURE INCLUDES

ENGINE MALFUNCTION INCLUDES

LOW ENGINE OIL PRESSURE INCLUDES

LOW HYDRAULIC CHARGING
PRESSURE INCLUDES

HYDRAULIC OIL FILTER RESTRICTION INCLUDES

HIGH HYDRAULIC OIL TEMPERATURE INCLUDES

INDICATOR LIGHTS

ENGINE PRE-HEATING INCLUDES

PARKING BREAK INCLUDES

NOTICE TO PLACE THE SAFETY BAR INCLUDES

1 TOOL KIT

HYDRAULIC BOTTLE JACK 20 TON
ACTION LEVER
JACK KEY

TYPE I WHEEL WRENCH 32X30
FORCE LEVER

WHEEL LOCK STUDS (2 UNITS) POLYURETHANE
6,2 KG
39,4X21,6X21 CM (LXAXH)

TOOLBOX PLIERS
SCREWDRIVER
PHILLIPS SCREWDRIVER
10" SPANNER
COMBINATION WRENCHES
(10 TO 23)MM

EXTINGUISHER (SUPPORT IN CABIN) PQS TYPE
CLASS A,B,C FIRES
10 KG

MEDICINE CABINET ANTISEPTIC ALCOHOL
OXYGENATED WATER
POROUS ADHESIVE TAPE
GAUZE
COTTON
BANDAGE (1 TRIANGULAR
-1 LONGITUDINAL)
SCISSORS
ANALGESICS (PARACETAMO
IBUPROFEN)
GLOVES

FLASHLIGHT LED TYPE

SAFETY TRIANGLES 2 UNITS 2 UNITS
50 CM EACH SIDE
FLUORESCENT SURFACE
ABS MATERIAL
RED REFLECTIVE PLATE
POLYETHYLENE BASE
(WEIGHT 2KG)

DIMENSIONS

- A. OVERALL OPERATIONAL HEIGHT
- B. BUCKET HINGE BOLT
- C. CAB TOP
- D. BOTTOM OF BUCKET LEVEL, WITH BUCKET ARM LOADER FULLY RAISED

TOTAL LENGTH:

- E. WITHOUT ACCESSORIES, WITH COUPLING DEVICE
- F. WITH BUCKET FOR CASTING/EXCAVATION AT LEVEL GROUND
- G. DUMP ANGLE AT MAXIMUM HEIGHT
- H. DUMPING HEIGHT – LOADER ARM FULLY RAISED
- J. REACH – LOADER ARM FULLY RAISED
- K. BUCKET ON GROUND LEVEL
- L. BUCKET AT MAXIMUM HEIGHT
- M. DISTANCE BETWEEN WHEEL CENTERS
- P. CLEARANCE FROM THE GROUND (BOTTOM OF THE SHEET OF PROTECTION)
- Q. OUTPUT ANGLE
- R. WITHOUT THE BUCKET
- S. WITH BUCKET FOR CASTING/EXCAVATION
- T. REAR TURNING RADIUS
- U. REAR AXLE TO BUMPER
- V. MACHINE GAUGE, MEASURED BETWEEN WHEEL CENTERS

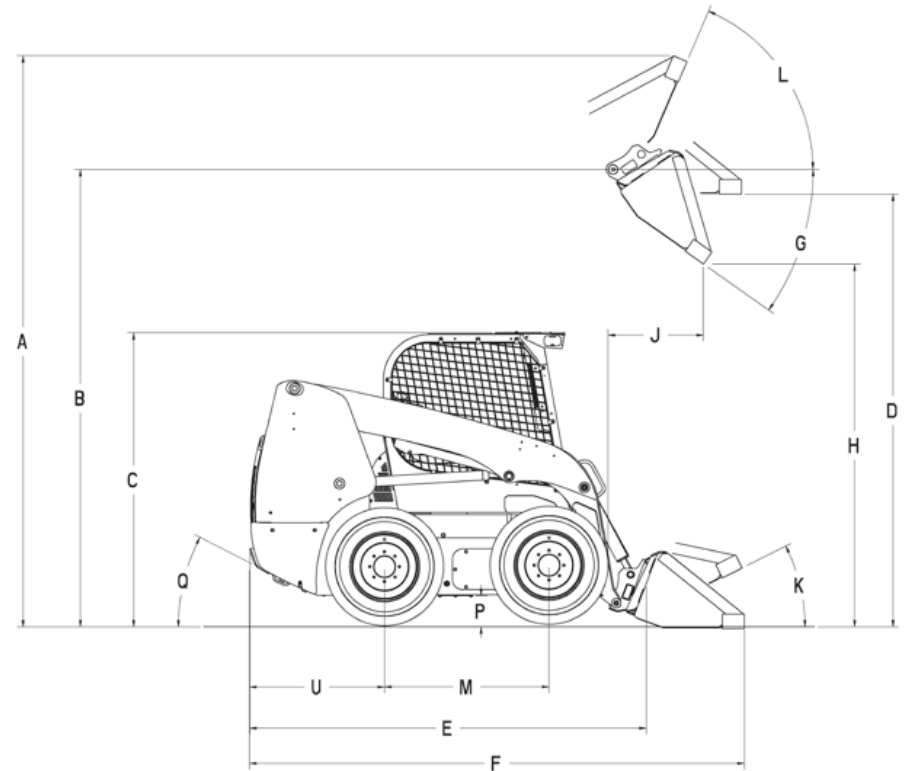
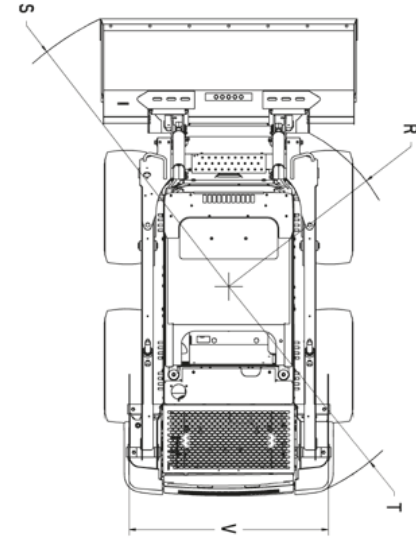

HYDRAULIC HAMMER - FOR MINI LOADER

HYDRAULIC HAMMER

BRAND YANWA

MODEL MH396

COUPLING FOR SKID STEER

OPERATING WEIGHT 396KG

IMPACT FREQUENCY 650-1550 STROKES/MIN

HYDRAULIC PRESSURE 12-16MPA

OIL FLOW 45-83 LITERS/MIN

POINTER DIAMETER 69MM



ANGLED SWEEPER - FOR MINI LOADER

ANGLED SWEEPER

BRAND	YANWA
MODEL	BH2250
COUPLING	FOR SKID STEER
OPERATING WEIGHT	460KG
SWEEP WIDTH	2250MM
BRUSH DIAMETER	610MM (53 BRUSHES)
HYDRAULIC FLOW	59 ~ 95 L/MIN
HYDRAULIC PRESSURE	240 BAR



HYDRAULIC TILLER - FOR MINI LOADER

HYDRAULIC MILLING MACHINE

BRAND	YANWA
MODEL	CP406
COUPLING	FOR SKID STEER
MILLING WIDTH	406MM
OSCILLATION	$\pm 15^{\circ}$
OPERATING WEIGHT	650KG
HYDRAULIC FLOW	52 ~101 L/MIN
HYDRAULIC PRESSURE	224 BAR
MILLING DEPTH	0 ~127MM



