



YANWA
YR-CTYD3



GARBAGE LOADER





BACKHOE YR-CTYD3

CHARACTERISTICS

GARBAGE REAR LOADER TRUCK

BRAND	YANWA
MODEL	YR-CTYD3
YEAR OF PRODUCTION	2023
ORIGIN	CHINA
TYPE	WALKED CHASSIS
GVWR	26000KG

CABIN

TYPE	FOLDING
MATERIAL	METAL (SHEET STEEL)
COLOR	
PASSENGERS	2 (DRIVER AND PASSENGER)
PASSENGER SEAT	SEAT BELT (3 FIXING POINTS) AIR SUSPENSION PNEUMATICALLY ADJUSTABLE SEAT
DRIVER SEAT	SEAT BELT (3 FIXING POINTS) AIR SUSPENSION PNEUMATICALLY ADJUSTABLE SEAT

CLUTCH

TYPE	SINGLE DRY DISC (REINFORCED)
DIAMETER	430MM
DRIVE	HYDRAULIC



ENGINE

BRAND	YANWA
MODEL	YM7,7-330
TYPE	4-STROKE INTERNAL COMBUSTION
FUEL	DIESEL
INJECTION SYSTEM	COMMON RAIL DIRECT INJECTION ELECTRONICS
COMBUSTION	INTERNAL 4 TIMES
POWER	330 HP AT 2,200 RPM (246 KW AT 2,200 RPM)
CYLINDER CAPACITY	7.7CC
NO. OF CYLINDERS	6 IN LINE
TORQUE	1200NM AT 1600RPM
EMISSIONS SYSTEM	EURO III
INTAKE SYSTEM	INTERCOOLED TURBO
ENGINE BRAKE	IN VALVES AND EXHAUST
FUEL TANK	348L (92GL) WITH WATER SEPARATOR FILTER - FUEL
REFRIGERATION	BY WATER





TRANSMISSION

TYPE	MANUAL/MECHANICAL
TYPE OF SYSTEM	SYNCHRONIZED
NUMBER OF GEARS	FORWARD (9)/ REVERSE (1)
OPERATION TYPE	BY WIRES
TRACTION	6X4

BRAKES

SERVICE BRAKE	DRUM FULL DOUBLE AIR CIRCUIT (PNEUMATIC) ABS INTEGRATED AIR DRYER
PARKING BREAK	PNEUMATIC LOCKING VALVE FOR REAR WHEELS TIRE TYPE
AUXILIARY BRAKE (ENGINE BRAKE)	TO VALVES AND EXHAUST RESTRICTION VALVE

ELECTRIC SYSTEM-INCLUDES

RATED VOLTAGE	24V
NO. BATTERIES	2
BATTERY TYPE (EACH)	12V/165AH
INCLUDES	DAY LIGHTS HEADLIGHTS FRONT HALOGENS REAR LIGHTS DIRECTIONAL LIGHTS (FRONT AND REAR) REVERSING LIGHTS LATER HALOGENS STROBE LIGHT (1 ON CABIN) ELECTRIC HORN BACKUP ALARM CENTER LOCK

SUSPENSION SYSTEM

FRONT SUSPENSION	9 SEMI-ELLIPTIC CROSSBOW BLADES ON RIGID SHAFT STABILIZER BAR DOUBLE ACTION TELESCOPIC SHOCK ABSORBERS
REAR SUSPENSION	TANDEM 12 SEMI-ELLIPTIC CROSSBOW BLADES FLOATING TYPE
FRONT AXLE	LOAD CAPACITY 8000 KG RIGID SHAFT
REAR AXLE	LOAD CAPACITY 13000KGX2 (26000KG) SINGLE REDUCTION AXLE WITH REDUCTION HUBS

ADDRESS

TYPE	RE-CIRCULATING BALLS
SYSTEM	HYDRAULICALLY ASSISTED

MUD GUARD (REAR WHEELS)

MATERIAL	METAL
----------	-------

DASHBOARD AND GAUGES

INCLUDES	FUEL GAUGE ENGINE OIL PRESSURE GAUGE AIR PRESSURE GAUGE BATTERY CHARGE INDICATOR FUEL LEVEL INDICATOR ENGINE TEMPERATURE GAUGE SPEEDOMETER ODOMETER TACHOMETER
----------	--

HYDRAULIC PUMP

TYPE	GEARS
FLOW	20 GPM @ 1200 RPM
TRUCK PTO TYPE	CARDAN COUPLE

CYLINDERS

COMPACTION CYLINDER (2 UNITS)	4.1/2" DOUBLE ACTING, CHROME STEM
SWEEPING CYLINDER (2 UNITS)	4.1/2" DOUBLE ACTING, CHROME STEM
EJECTOR CYLINDER (1 UNIT)	DOUBLE ACTING-4 STAGES 5.1/2", WITH NITRIDED STEM
HOPPER LIFT CYLINDER (2 UNITS)	3.1/2" SINGLE ACTING, CHROME STEM

EXTERNAL DIMENSIONS OF THE DRAWER

TOTAL LENGTH TAILGATE CLOSED	7112MM
TOTAL LENGTH TAILGATE OPEN	8077MM
TOTAL HEIGHT TAILGATE CLOSED	3073MM
FULL HEIGHT TAILGATE OPEN	4445MM
HOPPER INNER WIDTH	2052MM
HOPPER OPENING HEIGHT	1448MM
FULL WIDTH WITH STEPS	2591MM
TOTAL HEIGHT OF THE BOX FROM THE FRAME	2438MM
CAB TO FRAME LENGTH	5486MM

TIRES

AMOUNT	10 WHEELS(WITH RIMS)
EMERGENCY	1 WHEEL WITH RING AND SUPPORT BASE
NUMERATION	295/80 R22.5
NO. OF CANVASESTION	18
MAX LOAD PER WHEEL	3350KG
INFLATION PRESSURE	131PSI
TILLING DEPTH	20MM

COLLECTING BOX

BRAND	YANWA
ORIGIN	CHINA
YEAR	2023
BOX CAPACITY	25 YD3 / 19.1 M3
HOPPER CAPACITY	3 YD3 / 2.3 M3
CHARGING WAY	LATER
UNASSEMBLED BOX WEIGHT	6300KG
LUBRICATION TYPE MOVING ELEMENTS	MANUAL (LUBBER)
POST DISCHARGE	EJECTOR PANEL
COVERING	HIGH PERFORMANCE POLYURETHANE PAINT AND HIGH SOLIDS BLUE COLOR OR TO BE AGREED WITH THE BUYER
OIL TANK CAPACITY	170 LT (45 GL) WITH SIGHT GLASS
FILTERS	IN RETURN LINE FILTERING CAPACITY OF 10 MICRAS (MICRONS) IN MESH 100 SUCTION LINE BREATHING FILTER IN TANK COVER
OPERATING PRESSURE	175BAR (2538PSI)
COMPACTION CYCLES	18 - 22 SEC
DISCHARGE CYCLES	30 - 35 SEC



DRAWER CONTROL VALVES

VALVE A

TYPE	DOUBLE VALVE
DRIVE	LEVERS
LEVERS LOCATION	FRONT LEFT
DISCHARGE CONTROL SYSTEMS	EJECTOR PANEL REAR HOPPER LIFT

VALVE B

TYPE	DOUBLE VALVE
DRIVE	LEVERS
LEVERS LOCATION	HOPPER RIGHT SIDE
CONTROL SYSTEMS	COMPACTION PANEL SWEEP PANE

SYSTEM ALLOWS STOPPING AND REVERSING THE CYCLE AT ANY TIME (ANSI Z 245.1 STANDARD)

DRAWER INCLUDES

STIRRUPS	FOR 3 OPERATORS
HANDLES	FOR 3 OPERATORS
AUDIBLE ALARM (DRIVER AND OPERATORS COMMUNICATION)	YEAH
LEACHATE CHUTE	100 LT CAPACITY BETWEEN BOX AND HOPPER (LOWER)
SOUND SYSTEM	SOUND AMPLIFIER 24V TO 110V POWER CONVERTER EXTERNAL HORN 6GB USB FLASH DRIVE





CONSTRUCTION MATERIALS OF BOX - HOPPER

MATERIAL	A572 STRUCTURAL STEEL (GRADE 50 AND GRADE 70)
FLOOR BOX	GRADE 50 THICKNESS 5MM
BOX SIDE WALLS	GRADE 50 THICKNESS 4.75MM
ROOF BOX	GRADE 50 THICKNESS 3MM
HOPPER FLOOR	HARDOX AR450 THICKNESS 6MM
HOPPER LOWER SIDES	GRADE 70 THICKNESS 4.75MM
COMPACTOR PLATE	GRADE 50 THICKNESS 4.75MM
SWEEPING BLADE	GRADE 50 THICKNESS 4.75MM, CONCAVE SURFACE
COMPACTOR PLATE GUIDES	LONG-LASTING POLYMER SHIMS
EJECTOR PANEL GUIDES	GRADE 50 THICKNESS 6MM SEPARATED FROM THE FLOOR (AVOIDS ACCUMULATION OF RESIDUES)

CABIN INCLUDES

INCLUDES

RADIO (AM/FM +
USB PORT + BLUETOOTH)
HEATING / VENTILATION
(4 SPEED SURROUND)
WINDOWS (ELEVATION
ELECTRIC MOTOR)
A/C
CONTROL PANEL
STANDARD LIGHTS
HALL LIGHTS
LIGHTS IN DOORS
COMPLETE KIT OF MIRRORS
REARVIEW MIRRORS
(ELECTRIC)
BLIND SPOT MIRRORS
STEERING COLUMN
(ADJUSTABLE)
CABIN LIFTING SYSTEM
(ELECTRIC)
NEBLINEROS
3-SPEED WINDSHIELD WIPER
(INTERMITTENT)
3CENTER CONSOLE WITH
CUP HOLDER

TOOLS (1 KIT PER ROAD TEAM - TIPPER)

HYDRAULIC BOTTLE
JACK

15 TONS
ACTION LEVER
JACK KEY

TYPE I WHEEL
WRENCH

32X30
FORCE LEVER

WHEEL LOCK STUDS
(2 UNITS)

POLYURETHANE
6.2KG
39.4X21.6X21 CM (LXWXH)

TOOLBOX

PLIERS
SCREWDRIVER
PHILLIPS SCREWDRIVER
COMBINATION WRENCHES
(10 TO 23)MM

FIRE EXTINGUISHER
(SUPPORT IN CABIN)

PQS TYPE
CLASS A,B,C FIRES
10KG

FIRST AID KIT

RUBBING ALCOHOL
HYDROGEN PEROXIDE
POROUS ADHESIVE TAPE
GAUZE
COTTON
BANDAGE (1 TRIANGULAR
- 1 LONGITUDINAL)
SCISSORS
ANALGESICS (PARACETAMOL
-IBUPROFEN)
GLOVES

FLASHLIGHT

LED TYPE

SAFETY TRIANGLES

2 UNITS
50 CM EACH SIDE
FLUORESCENT SURFACE
ABS MATERIAL
RED REFLECTIVE PLATE
POLYETHYLENE BASE
(WEIGHT 2KG)

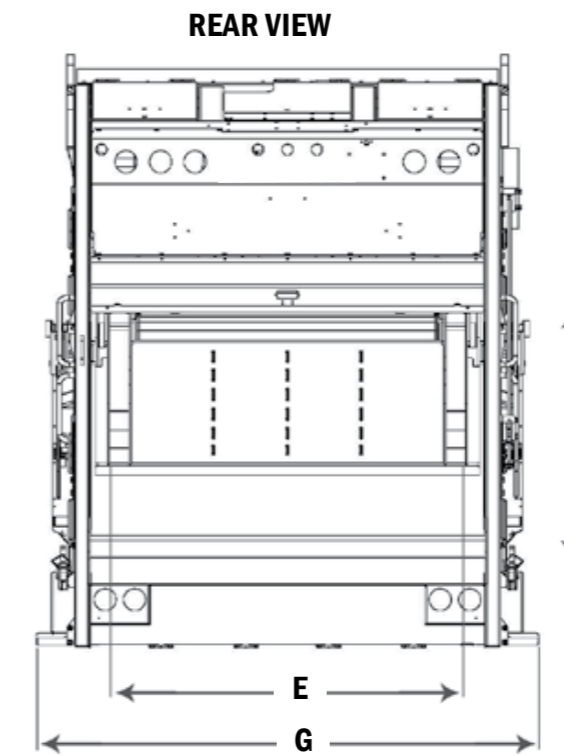
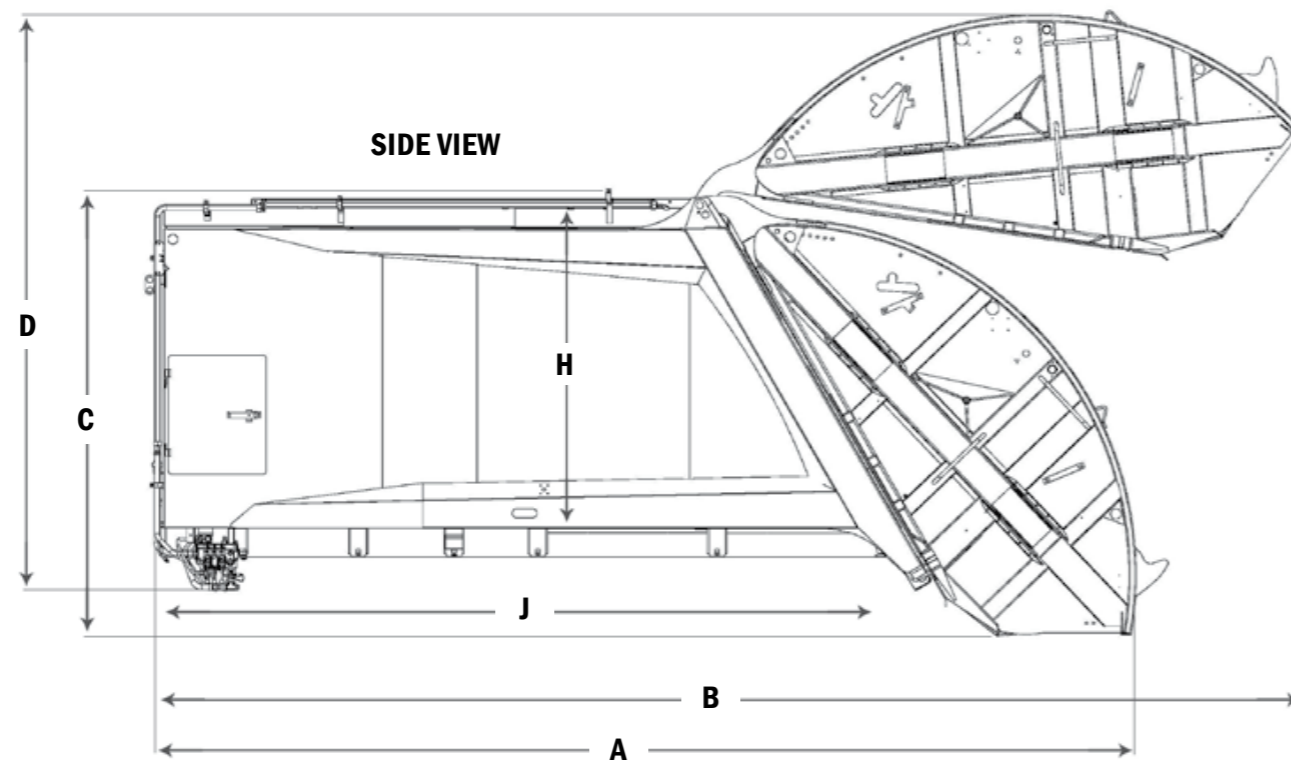

WEIGHTS AND DIMENSIONS

DESCRIPTION	13 M ³ (17 YD ³)		15.3 M ³ (20 YD ³)		19.1 M ³ (25 YD ³)		21.4 M ³ (28 YD ³)	
unmounted body weight	5760 kg	12672 lb	5990 kg	13178 lb	6300 kg	13860 lb	6570 kg	14454 lb
(A) Overall Length, Gate closed back	5918 mm	233 in	6325 mm	249 in	7112 mm	280 in	7595 mm	299 in
(B) Overall Length, Gate raised rear	6553 mm	258 in	7112 mm	280 in	8077 mm	318 in	8560 mm	337 in
(C) Total height, Gate closed back**	3073 mm	121 in	3073 mm	121 in	3073 mm	121 in	3073 mm	121 in
(D) Total height, Gate raised rear**	4445 mm	175 in	4445 mm	175 in	4445 mm	175 in	4445 mm	175 in
(E) Width inside the hopper	2032 mm	80 in	2032 mm	80 in	2032 mm	80 in	2032 mm	80 in
(F) Hopper opening height	1448 mm	57 in	1448 mm	57 in	1448 mm	57 in	1448 mm	57 in
(G) Full width with steps	2591 mm	102 in	2591 mm	102 in	2591 mm	102 in	2591 mm	102 in
(H) height above frame	2438 mm	96 in	2438 mm	96 in	2438 mm	96 in	2438 mm	96 in
(J) cab to frame	4216 mm	166 in	4572 mm	180 in	5486 mm	216 in	5969 mm	235 in

*Base weight of the body without any options included

**Dimension without winch. The addition of a reel winch increases the height dimension.

