



WHEEL FRONT LOADER

CF870-2H





## FRONT LOADER

BRAND	YANWA
MODEL	CF870-2H
YEAR OF PRODUCTION	2023
ORIGIN	CHINA
OPERATIONAL WEIGHT	19200KG

## CABIN

CABIN	CLOSED
GUY	ROPS (ISO 3741) / FOPS (ISO 3449)
A/C	INCLUDES
ERGONOMIC / ADJUSTABLE SEAT	INCLUDES
SEAT BELT	INCLUDES
EXTERNAL REARVIEW MIRRORS (ONE RIGHT / ONE LEFT)	INCLUDES
CABIN REAR VIEW MIRROR (ONE INSIDE CAB)	INCLUDES
RADIO (BLUETOOTH+USB+AM/FM)	INCLUDES
NOISE INSIDE THE CABIN	72.3DB(A)
NOISE OUTSIDE THE CABIN	82.4DB(A)



## ENGINE

BRAND	CUMMINS
MODEL	QSL9,3
TYPE	4-STROKE INTERNAL COMBUSTION
FUEL	DIESEL
NET POWER	239HP
OPERATING REGIME	2200RPM
DISPLACEMENT	9.3L
EMISSIONS SYSTEM	TIER 3
CYLINDER CAPACITY	9300CC
MAXIMUM TORQUE (TORQUE)	1187 NM @ 1300 RPM
NUMBER OF CYLINDERS	6 IN LINE
AIR SUPPLY	TURBOCHARGED/AFTERCOOLED
ADDITIONAL FUEL FILTER	INSTALLATION OF AN ADDITIONAL FUEL FILTER SYSTEM IS INCLUDED - TYPE AK
FUEL TANK CAPACITY	280 LITERS
RADIATOR FAN	HYDRAULICALLY DRIVEN ELECTRONICALLY CONTROLLED ROLLBACK SYSTEM

## TRANSMISSION

TRACTION	4WD (4X4)
TYPE	POWER SHIFT
SPEEDS	4 FORWARD / 3 REVERSE
TOP SPEED 1ST (FORWARD /REVERSE)	6.45 KM/H
MAX SPEED 2ND (FORWARD /REVERSE)	11.8 KM/H
3RD MAX SPEED (FORWARD/ REVERSE)	25.25 KM/H
TOP SPEED 4TH (FORWARD)	40.0KM/H
TRANSMISSION TYPE	POWER ASSISTED
MODES OF CHANGE	ELECTRO - HYDRAULIC CONTROLS
FRONT AND REAR DIFFERENTIAL	LIMITED SLIP TYPE ( LIMITED SLIP)

## STANDARD DIMENSIONS

HEIGHT UP TO CABIN	3550MM
WIDTH OVER TIRES	2980MM
LENGTH WITH BUCKET ON THE GROUND	8679MM
DISTANCE BETWEEN AXIS	3550MM

## DIRECTION SYSTEM

TYPE	HYDRAULIC / POWER ASSISTED LOAD SENSING CENTER JOINT
------	--

## HYDRAULIC SYSTEM

PUMP TYPE	VARIABLE DISPLACEMENT AXIAL PISTON PUMP
-----------	--

LOAD SENSING	INCLUDES
--------------	----------

FLOW (PUMP FLOW)	286 L/MIN
------------------	-----------

TYPE OF SYSTEM	CLOSED CENTER
----------------	---------------

SYSTEM PRESSURE	4249 PSI / 29300 KPA
-----------------	----------------------

HYDRAULIC SYSTEM CAPACITY	180LT
---------------------------	-------

DEPOSIT CAPACITY	100LT
------------------	-------

LOADER/STEER CONTROL	JOYSTICK PILOT
----------------------	----------------

## BRAKES

SERVICE BRAKE	MULTIPLE DISC - OIL BATH EXTERNAL BUILT IN 4 WHEELS HYDRAULIC ACTUATOR
---------------	---

PARKING BREAK	DISK SPRING MECHANISM HYDRAULIC RELEASE ACTUATION ON EXTERNAL AXIS OF THE TRANSMISSION
---------------	---

## CHARGER

TYPE	HYDRAULIC
------	-----------

LADLE	GENERAL PURPOSE / REPLACEABLE TEETH
-------	--

CONTROLS	JOY STICK
----------	-----------

BUCKET CAPACITY	3.0 M3
-----------------	--------

BUCKET BREAKOUT FORCE	18253 KGF (179 KN)
-----------------------	--------------------

FULL HEIGHT LIFT CAPACITY	9050KG
---------------------------	--------

LIFTING CAPACITY AT GROUND LEVEL	15500KG
----------------------------------	---------

TIPPING LOAD IN A STRAIGHT LINE	19500KG
---------------------------------	---------

BUCKET WIDTH	2937MM
--------------	--------

MAX DUMP ANGLE	55° (FULL HEIGHT)
----------------	-------------------

FREE DOWNLOAD SPACE	3105MM
---------------------	--------

REACH AT MAXIMUM DUMP HEIGHT	1320MM
------------------------------	--------

PIN LOADING HEIGHT	4460MM
--------------------	--------

DIGGING DEPTH	85MM
---------------	------

## WHEELS

FRONT	DIMENSIONS 23.5 R25 L3 MAX LOAD 9250KG
-------	---

LATER	DIMENSIONS 23.5 R25 L3 MAX LOAD 9250KG
-------	---

## ELECTRIC SYSTEM

VOLTAGE	24 VOLTS
BATTERY VOLTAGE EACH	12
BATTERY CAPACITY EACH	925 CCA
ALTERNATOR	150A

### ELECTRICAL SYSTEM - INCLUDE

WORK LIGHTS (4 FRONT LED LIGHTS / 4 REAR LED LIGHTS)	INCLUDES
HIGHWAY TRAFFIC LIGHTS	INCLUDES
WARNING LIGHTS	INCLUDES
ELECTRIC HORN	INCLUDES
BACKUP ALARM	INCLUDES

### DASHBOARD - INCLUDES

TACHOMETER	INCLUDES
HYDROMETER	INCLUDES
HOUR METER	INCLUDES
SPEEDOMETER	INCLUDES
ENGINE TEMPERATURE GAUGE	INCLUDES
HYDRAULIC OIL TEMPERATURE GAUGE	INCLUDES
FUEL METER	INCLUDES
WARNING LIGHTS	INCLUDES

## BACKHOE TOOLS

HYDRAULIC BOTTLE JACK	20 TON ACTION LEVER JACK KEY
TYPE I WHEEL WRENCH	32X30 FORCE LEVER
WHEEL LOCK STUDS (2 UNITS)	POLYURETHANE 6,2 KG 39,4X21,6X21 CM (LXAXH)
TOOLBOX	PLIERS SCREWDRIVER PHILLIPS SCREWDRIVER 10" SPANNER COMBINATION WRENCHES (10 TO 23)MM
EXTINGUISHER	PQS TYPE CLASS A,B,C FIRES 10 KG
MEDICINE CABINET	ANTISEPTIC ALCOHOL OXYGENATED WATER POROUS ADHESIVE TAPE GAUZE COTTON BANDAGE (1 TRIANGULAR -1 LONGITUDINAL) SCISSORS ANALGESICS (PARACETAMO IBUPROFEN) GLOVES
FLASHLIGHT	LED TYPE
SAFETY TRIANGLES 2 UNITS	2 UNITS 50 CM EACH SIDE FLUORESCENT SURFACE ABS MATERIAL RED REFLECTIVE PLATE POLYETHYLENE BASE (WEIGHT 2KG)

## LOADER ARM PERFORMANCE

Tipping Load - Straight  
Carga de Vuelco - Giro Total

Bucket Breakout Force

A Maximum Tie Rod Height

B Clearance at Maximum Dump Height

C Reach at Maximum Dump Height

D Excav Depth Max Bucket Level

S<sub>1</sub> Bucket Return to Ground Level

S<sub>2</sub> Bucket Return in Transport

S<sub>3</sub> Bucket Return to Full Height

S<sub>4</sub> Maximum Dump Angle at Maximum Height

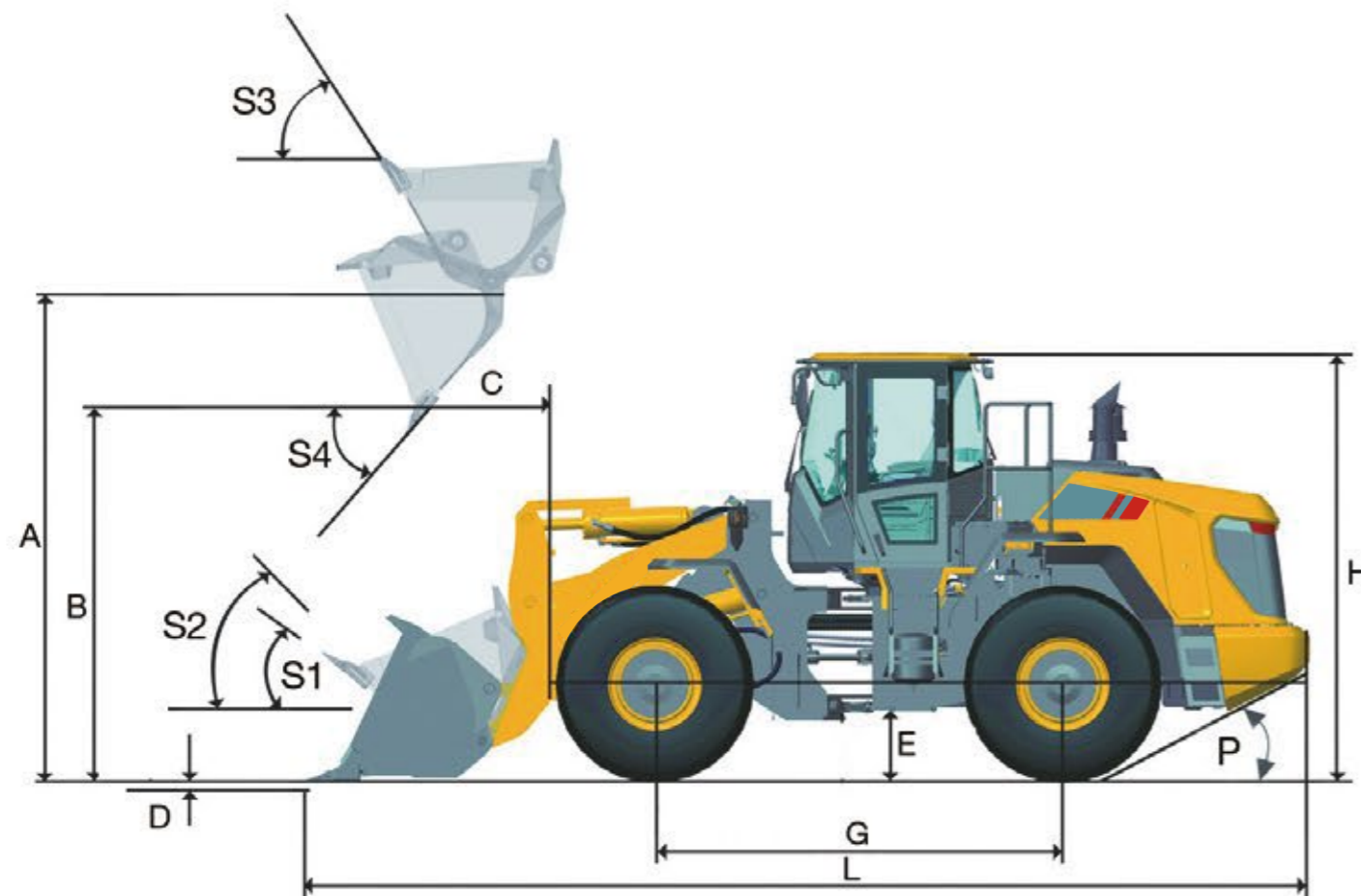

## DIMENSIONS

E Ground Clearance

G Wheelbase

H Cab Height

J Tread Ban

K Width over Tires

M Turning Angle, Both Sides

P Rear Departure Angle

R<sub>1</sub> Radius of Turn, Bucket Carry

R<sub>2</sub> Radius of Turn, Tire Surface

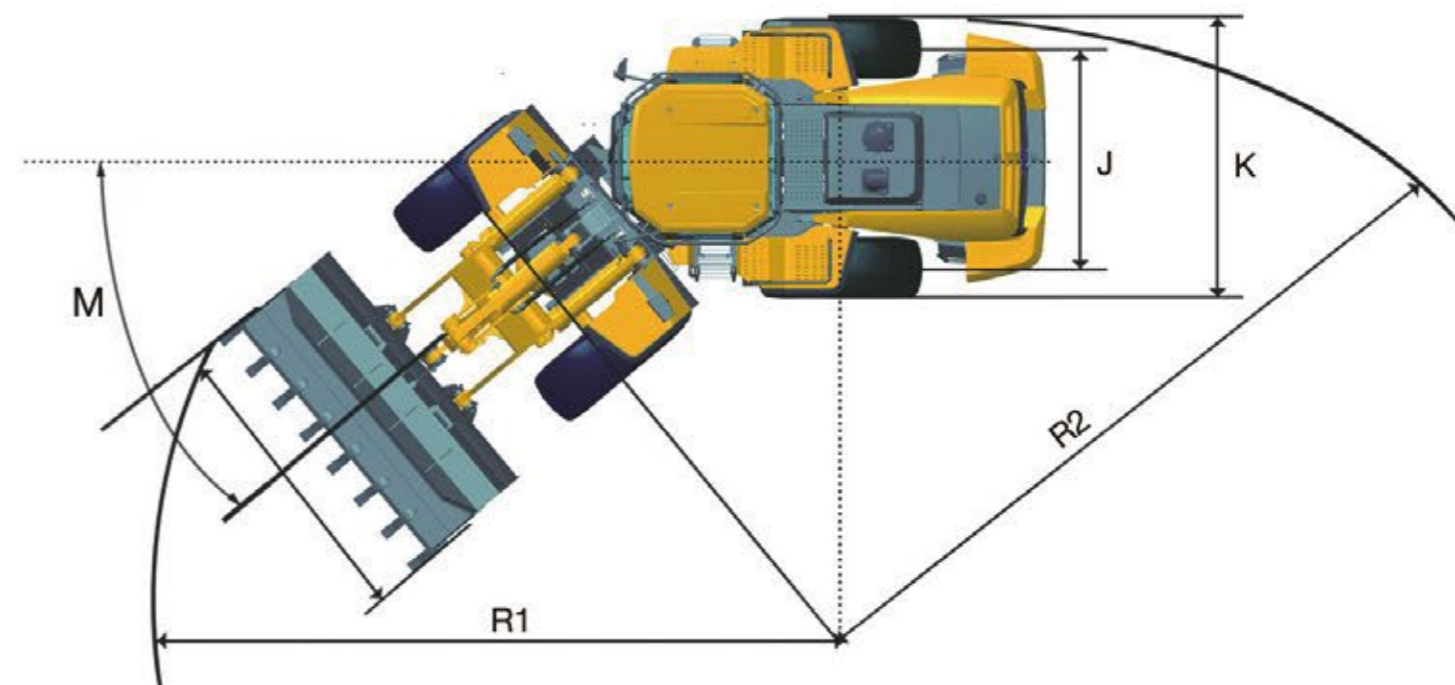





**YANWA**  
PROFESSIONAL MACHINERY

**YANWA**  
PROFESSIONAL MACHINERY

**YANWA**  
PROFESSIONAL MACHINERY

**YANWA**  
PROFESSIONAL MACHINERY